

Meet New Generation of Additive Manufacturing



Difference is Value
DMT[®] Metal AM Technology Specialist

InssTek

MX-Fab Series

DED Machine With DMT & 5-Axis System

Features

- All in one system for fabrication
- 5-Axis system & DMT technology
- Accurate & Stable CVM powder feeding system applied
- Hexa-Feeding system for multi materials
- Efficient inert gas control system
- Easiest installation
- Compact size & efficient build volume



"All in one system for fabrication"

Laser generator & chiller

Technical Data

	MX-Fab 1	MX-Fab 3
Laser Power Ytterbium Fiber Laser (W)	1000 (Max. 2000)	2000
X / Y / Z Stroke (mm) A / C Stroke (deg)	500 × 600 × 385 - 100 ~ + 100 / 360	800 × 1000 × 700 - 100 ~ + 100 / 360
Optic Module Beam Diameter(um)	LFM Series 800 / 1200 / 1600 / 2400	
Powder Feeding System	PCM-Multi (Max. 6 hoppers)	
Software (OS / CAM) Feedback System	MX-OS / MiXO Pro DMT® Closed Loop Feedback Control system	
Atmosphere Control System (Option)	Gas : Argon(>99.999) / O ₂ Level : ≤ 50	

DMT® Technology

The Most Precise DED Technology

DMT® (Direct Metal Tooling)

InssTek's own technology which developed and categorized as DED (Direct Energy Deposition) technology according to ASTM standards. DMT technology can analyze and control the height of the melt pool in real-time with a vision camera(s).

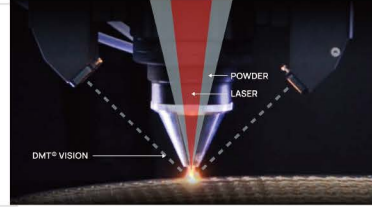

Applicable materials for DMT®

Titanium	Cp-Ti(Gd2), Ti-6Al-4V(Gd5, Gd23)	Hastelloy	22, 276
Steel	P20, P21, H13	Copper	Cu-Sn, Al-Bronze
Stainless Steel	304L, 316L, 420J2, 2507	Cobalt	CoCr, Stellite 6, 21, 25
Nickel	600, 625, 690, 713, 718, Invar36	Niobium	C-103

AM-Module

Compact Optic And Size-Changeable Beam

Various beam sizes up to 3x are available by replacing optic cartridge(LFM-1) or installing automatic zoom system(LFM-2).

LFM-2 NEW Launching Nov. 2024

Automatic zoom optics

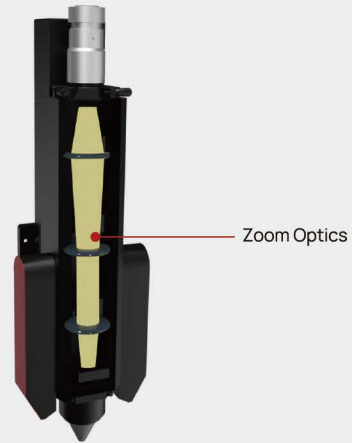

LFM-1

Select 4 different cartridge and change them easily

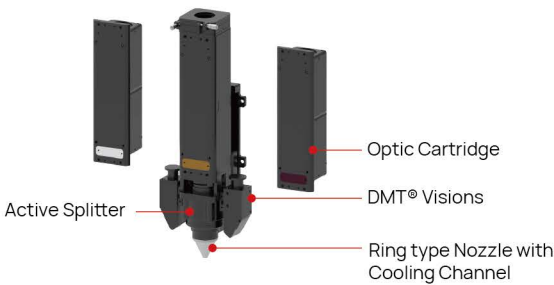

Technical Data

Type	SDM800	SDM1200	SDM1600	SDM2400
Beam Size (um)	800	1200	1600	2400
Build Speed (cm ³ /h)	5.8	16.4	27.4	66.6
Layer Height (um)	250	450	600	900

MX-Lab

DED & Material Research System

Features

- Simple system & easy entrance of DED
- Focus on material research
- 3-Axis system & DMT technology
- Accurate & Stable CVM powder feeding system applied (built-in)
- Hexa-Feeding system for multi materials



“Compact system for easy installation”

- CVM powder feeding system
- Cartridge type optics
- Laser generator
- E-Box, Stage, Pannel

Technical Data

	MX-Lab
Laser Power Ytterbium Fiber Laser (W)	Max. 500
X / Y / Z Stroke (mm)	150 × 150 × 150
Optic Module / Beam Diameter (um)	SDM 400 / 400
Powder Feeding System	Built-in CVM powder feeding system (Max. 6 hoppers)
Software (OS / CAM) Feedback System	MX-OS for MX-Lab / Material Designer & MiXO DMT® Closed Loop Feedback Control system
Atmosphere Control System (Option)	Gas : Argon(>99.999%) / O ₂ Level : ≤ 50ppm

MX-Lab Function

Built-in feeder

The MX-Lab's built-in CVM powder feeding system with multiple hoppers are optimized for High entropy alloy(HEA) research. It can speed-scan alloys of various compositions when 3D printing is performed, so material research can be carried out quickly.

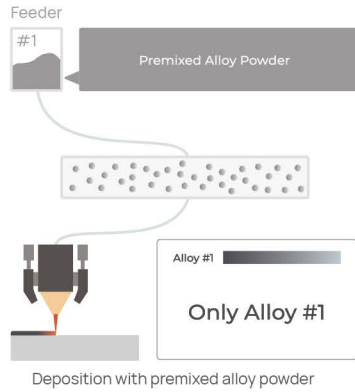
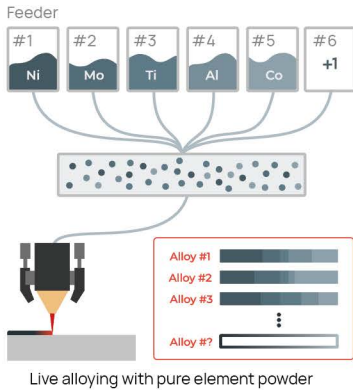

Auto Z

The function to automatically adjust the distance between sample and nozzle to WOP(9mm) layer by layer during deposition.



Laser Control

The function to set the appropriate laser power for a material at the desired location based on NC-Code when producing a multi material sample.



MX-Med

Porous Coating System

Features

- Titanium porous structure application
- Technology developed to apply for orthopedic implant surface coating
- Used for artificial hip joint (FDA approved) & knee coating

Porous coating

Special Optic Module

Coating AM CAM

Simultaneous 5Axis Control

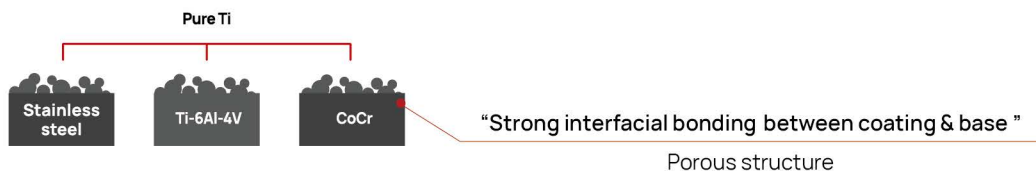

Technical Data

	MX-Med
Laser Power Ytterbium Fiber Laser (w)	Max. 100 (Dual Module available)
X / Y / Z Stroke (mm) A / C1,C2 Stroke	300 × 300 × 230 - 100 ~ + 5 / 360 / 360
Optic Module / Beam Diameter(um)	Porous Coating Module / 200
Powder Feeding System	PCM-Single
Software (OS / CAM)	MX-OS / MiXO Pro
Atmosphere Control System (Option)	Gas : Argon(>99.999%) / O ₂ Level : ≤ 50ppm

Metal Porous Coating

Medical Industry

Artificial joint coating

InssTek's MPC technology is able to coat pure titanium on various metals. In case of artificial joint, Hip system is made with Ti-6Al-4V and knee systems are made with CoCr. InssTek successfully made Ti porous layer on both Ti-6Al-4V and CoCr products.

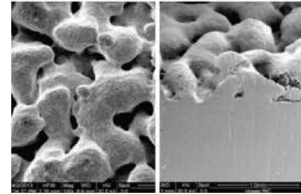

Top

Cross section

	Stem Component Hip System	Cup Component Hip System	Tibial Component Knee System	Femoral Component Knee System
				
Base Material	Ti-6Al-4V	Ti-6Al-4V	CoCr	CoCr
Coating Material	Pure Ti	Pure Ti	Pure Ti	Pure Ti

Semiconductor Industry

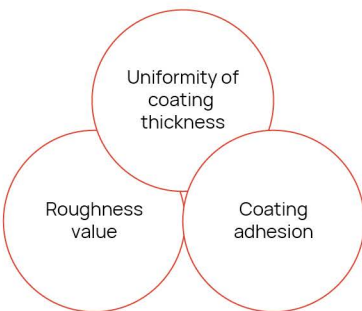

Increase productivity & efficiency



Component in the semiconductor industry

PCM Series

Accurate CVM Powder Feeding System

Stand-Alone and integrated system

- Easy installation
- Tiny amount of powder can be supplied
- Precise powder volume control & material minimum quantity control
- Patent powder feeding method & unique feedback system
- Real-time feedback with a unique method



PCM-Multi

Multi Material Fabrication

Features

- Hexa-powder feeding system (Max. 6 hoppers)
- Real-time feedback control
- Feeding rate range: 0.05~20.0g/min(based on Ti-6Al-4V)
- User-configurable mixture proportions for alloys
- Minimum quantity powder control
- Convenient storage unit



Newly developed feeding system

It can supply powder stably and accurately with real-time feedback control

PCM-Single

Suitable For Mass Production

Features

- Single-powder feeding system(1 hopper)
- Real-time feedback control
- Feeding rate range: 0.5~10.0g/min(based on Ti-6Al-4V)
- Continuous quality control function
- Steady material supply
- High-capacity hopper



CVM Powder Feeding System

Next Step Of Powder Feeding System

CVM (Clogged Vibration Method) system is a new type of powder feeding system. It has impressively stable powder feed rate, semi-permanent life time and broad feeding rate range. Also this system is applicable with gravity powder supply method and direct powder supply method with gas in DED process.

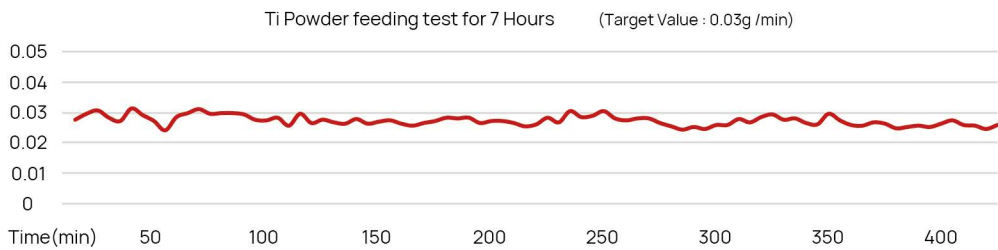
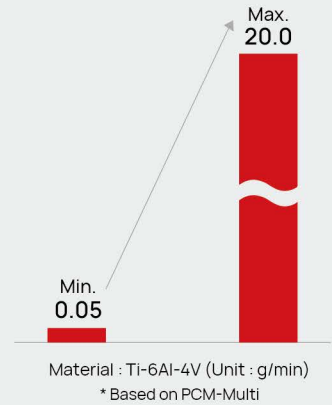

* The test was executed using MX-Lab machine.

Technical Data

	PCM-Multi	PCM-Single
Feeding Rate (g/min)	0.05 ~ 20.0 (based on Ti)	0.5 ~ 10.0 (based on Ti)
Powder Hopper Volume (Liter)	1	2.6
The Number of Feeder	Standard 2 (Max. 6)	1
Feedback System	Sampling	Sampling
Dimension (mm)	800 x 920 x 1370	293 x 376 x 1260
Communication Protocols	RS485	RS485 Analog signal (0 ~ 10V)

NARAE System

Large Scale Robot 3D Printing System

Features

Vertical stage with 6-Axis robotic arm / rotary stage
Printing volume: D 3.5(m) * H 7.5(m)
Compatible with InssTek printing system
Long time stable 3D printing with monitoring system



NARAE OS

Equipped With a Proprietary OS, Controllable Layered Process, And Monitorable Operations.

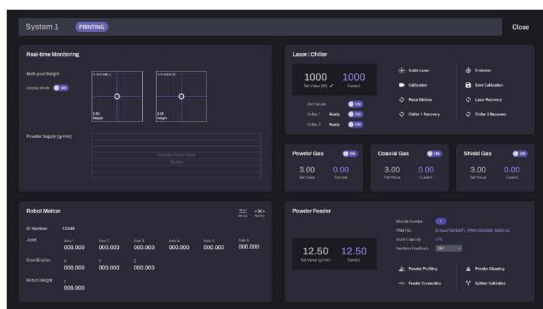
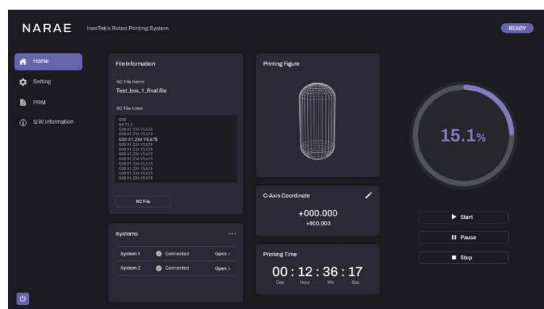

Rocket Nozzle

Size: D1 220mm, D2 876mm, H 1,087mm, T 2.5mm

Material: SS316L

Operating Time: 12 Days



MiXO Pro (AM-CAM Software)

Perfect Solution For Simultaneous 5-Axis AM CAM

Simultaneous 5-Axis AM-CAM is one of the most important technology of InssTek's DED additive manufacturing. Combined with InssTek's years of know-how, MiXO Pro enables us to overcome the limitations of existing DED technology. We are breaking the limits of additive manufacturing.

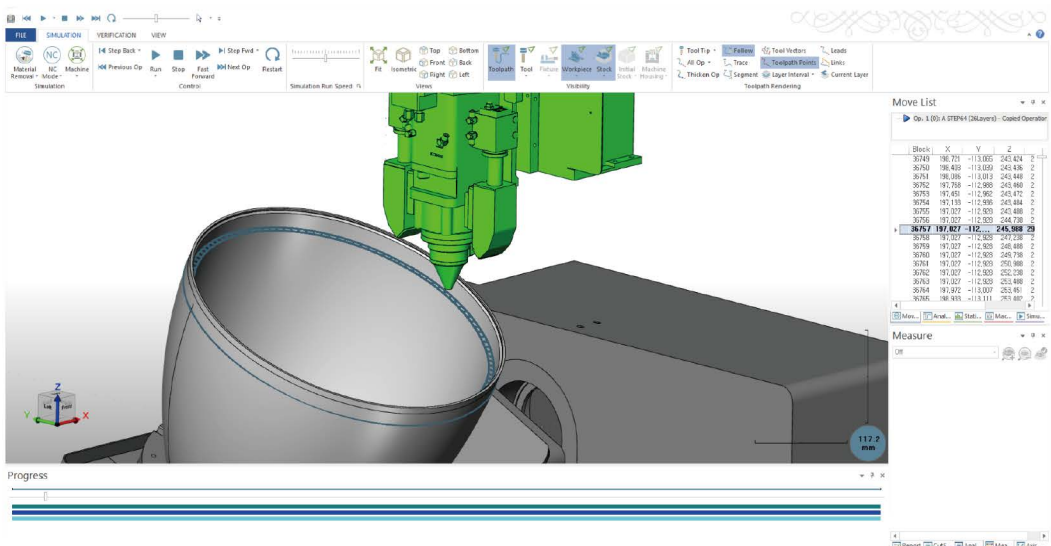
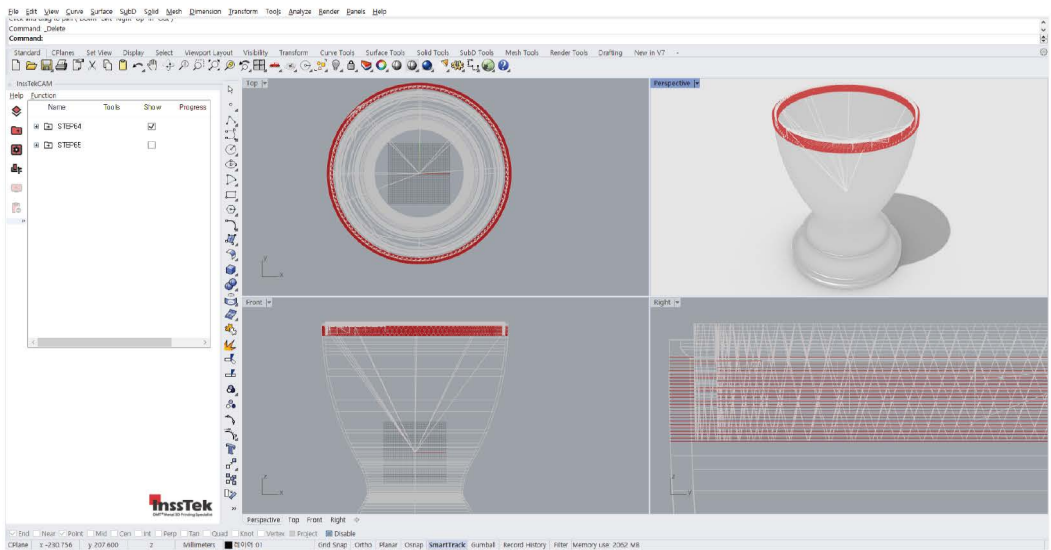



InssTek, Inc.

+82.42.935.9646 | sales@insstek.com | www.insstek.com